

Tracked minidumper
Raupentransporter

UTILITY LINE

TC45
TC50
TC50d
TC80
TC85
TC85d



general features

allgemeine eigenschaften

Rubber tracked minidumper, with hydraulic transmission controlled by manual levers with three gear pumps and fixed displacement orbital engines. Steering throughout independent rotation of the tracks. Innovative and patented cooling system by forced air.

Raupentransporter mit hydraulischem Getriebe, ausrüstbar mit austauschbaren Aufbauten für unterschiedliche Einsatzzwecke.

Hydraulisches Getriebe, handgesteuert, mit dreifacher Zahnradpumpe und Orbitalmotoren mit fixem Hubraum. Lenkung durch unabhängige Drehung der Raupenketten. Das innovative und patentierte Kühlsystem durch Zuluft ersetzt den herkömmlichen Kühler.

2nd travel speed operated by a lever on the hydraulic distributor.

Operational double effect P.T.O.

(not available in TC45, TC50 and TC50d version) with a delivery of max. 20 lt/min and pressure 150 bar.

Other flows/pressures are also available on specific demand.

Tracked undercarriage suitable for different specific applications.

Die zweite Bewegungsgeschwindigkeit kann durch den dazu bestimmten Hebel auf dem öldynamischen Verteiler betätigt werden.

Zapfwelle mit Einfachem - und Doppeleffekt, Option

(nicht verfügbar beim TC45, TC50 und TC50d) geeignet für den Anschluss von zusätzlichem Zubehör mit Förderleistung max 20 lt/min und Druck 150 bar. Auf Anfrage verschiedene Nutzlasten und hydraulische drücke verfügbar.

Raupenunterwagen für verschiedene Zwecke anwendbar.



technical data

technische daten

		TC45	TC50	TC50d	TC80	TC80d	TC85
Operational weight with shovel <i>without operator</i> Eigengewicht mit Schaufel <i>ohne Bediener</i>	kg kg	360 360	360 360	380 380	490 490	560 560	540 540
Max payload undercarriage Max Nutzlast Unterwagen	kg kg	500 500	500 500	500 500	800 800	850 850	850 850
Engine type - Air cooling Motot typ - Luft Kühlung		Petrol Benzin <i>Briggs & Stratton 750</i>	Petrol Benzin <i>Honda GX200</i>	Diesel Benzin <i>Yanmar L70N6</i>	Petrol Benzin <i>Honda GX270</i>	Diesel Benzin <i>Yanmar L100N6</i>	Petrol Benzin <i>Honda GX390</i>
Max. Power Max. Leistung	cv/kW PS/kW	5.5/4 5.5/4	4.8/6.5 4.8/6.5	6.6/4.9 6.6/4.9	9/6.6 9/6.6	10/7.4 10/7.4	13/9.6 13/9.6
Cylinder/Displacement Zylinder/Hubraum	n/m ³	1/163	1/196	1/320	1/270	1/406	1/389
Hydraulic system: 3 Gears pumps Hydraulischesystem: 3 Zahnradpumpe		2x12.5 lt/min@ 190 bar 1x14 lt/min@ 135 bar	2x12.5 lt/min@ 190 bar 1x14 lt/min@ 135 bar	2x12.5 lt/min@ 190 bar 1x19 lt/min@ 135 bar	2x20.5 lt/min@ 175 bar 1x20 lt/min@ 150 bar	2x20.5 lt/min@ 175 bar 1x20 lt/min@ 150 bar	2x20.5 lt/min@ 175 bar 1x20 lt/min@ 150 bar
N. 2 speeds I/II N. 2 Fahrgeschwindigkeiten I/II	Km/h	0-1.8/0-3.9	0-1.8/0-3.9	0-1.6/0-5.2	0-2.1/0-4.2	0-2.1/0-4.2	0-2.1/0-4.2
Specific ground pressure: empty/loaded Bodendruck: im Leerzustand/baladen	kg/cm ² kg/cm ²	0.118/0.254 0.118/0.254	0.118/0.254 0.118/0.254	0.151/0.240 0.151/0.240	0.166/0.335 0.166/0.335	0.190/0.360 0.190/0.360	0.181/0.350 0.190/0.360
Max.gradient capability with operational loading Max. befahrbare Steigung mit Betriebslast	% %	30 30	30 30	30 30	30 30	30 30	30 30
Fuel tank capacity Kraftstofftank	lt lt	3,6 3,6	3,6 3,6	3,3 3,3	6 6	5,5 5,5	6,5 6,5
Hydraulic oil tank capacity Hydrauliköltank	lt lt	18 18	18 18	18 18	22 22	30 30	30 30

overall dimensions in mm

abmessungen mm

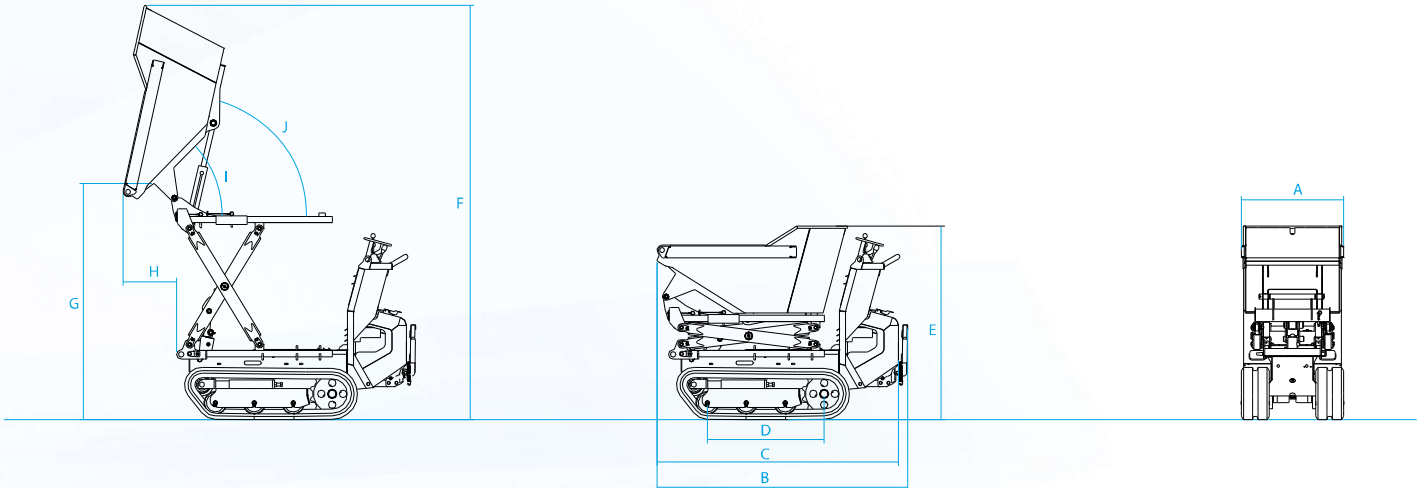

AV	A	B	C	D	E	F	G	H	I	J	K	L	M	N	O	P
TC45	700	660	480	842	1631	1600	497	41	967	1153	73	753	432	325	45°	76°
TC50	700	660	480	842	1631	1600	497	41	967	1153	73	753	432	325	45°	76°
TC50d	700	660	480	842	1631	1600	497	41	967	1153	73	753	432	325	45°	76°
TC80	830	790	610	842	1633	1746	496	41	967	1152	75	753	432	325	45°	76°
TC85d	830	790	610	842	1633	1746	496	41	967	1152	75	753	432	325	45°	76°
TC85	830	790	610	842	1633	1746	496	41	967	1152	75	753	432	325	45°	76°

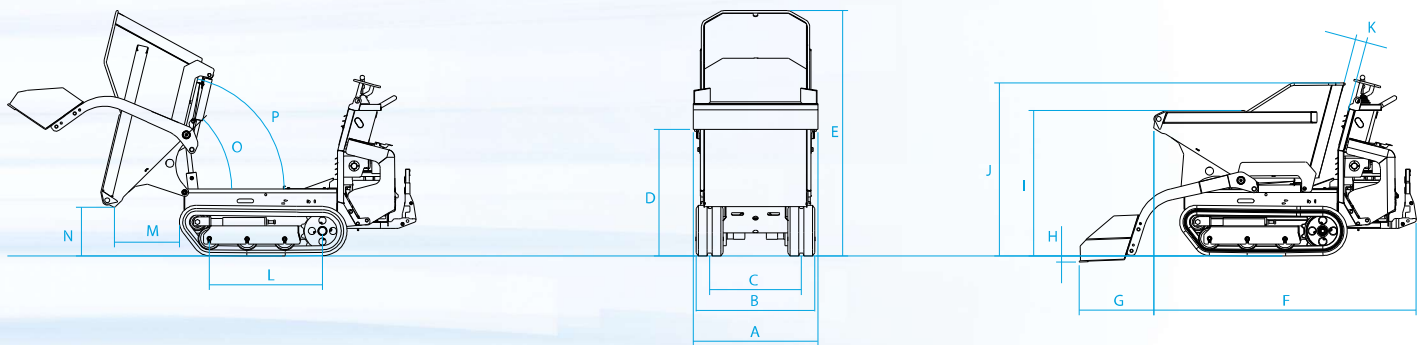

MTP	A	B	C	D	E	F	G	H	I	J	K	L	M
TC45	480	660	707	1254	753	1670	1180	225	550	800	1400	1210	53°
TC50	480	660	707	1254	753	1670	1180	225	550	800	1400	1210	53°
TC50d	480	660	707	1254	753	1670	1180	225	550	800	1400	1210	53°
TC80	610	790	840	1390	753	1720	1180	225	550	800	1400	1230	53°
TC85d	610	790	840	1390	753	1720	1180	225	550	800	1400	1230	53°
TC85	610	790	840	1390	753	1720	1180	225	550	800	1400	1230	53°

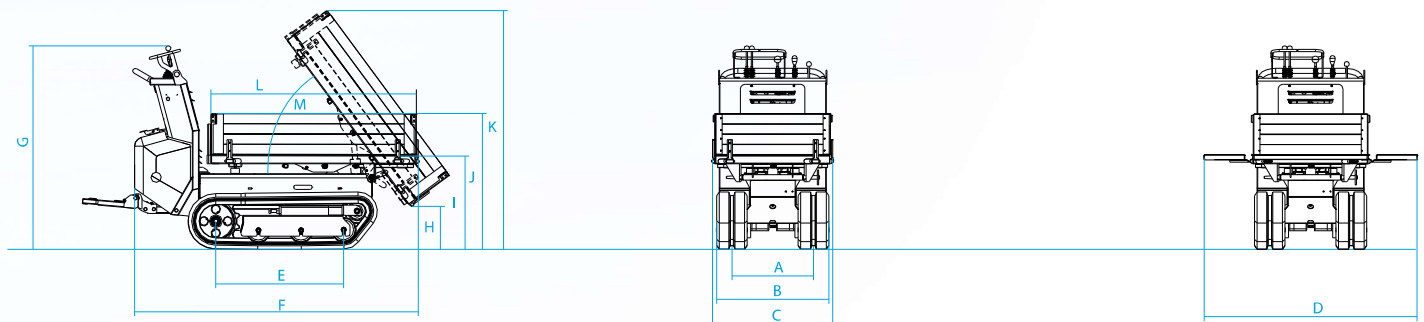

CA	A	B	C	D	E	F	G	H	I	J
TC50	660	1616	1555	753	1249	2671	1521	345	46°	78°
TC50d	660	1616	1555	753	1249	2671	1521	345	46°	78°
TC85d	790	1762	1701	753	1249	2671	1521	345	46°	78°

Data, features and pictures are not binding and may be altered without any prior notice.
 Änderungen ohne Ankündigung vorbehalten, Angaben ohne Gewähr.



Azienda certificata

via Arcevese, 44
60010 Casine di Ostra
Ancona, Italy
T +39 071 688771
F +39 071 68858
export@messersi.it
www.messersi.it

TC45 / TC50

TC50d

TC50d

TC80

TC85

TC85d

